

Chip & Dale Thanksgiving Basket



Chip & Dale Thanksgiving Basket

fold away from you

fold away from you

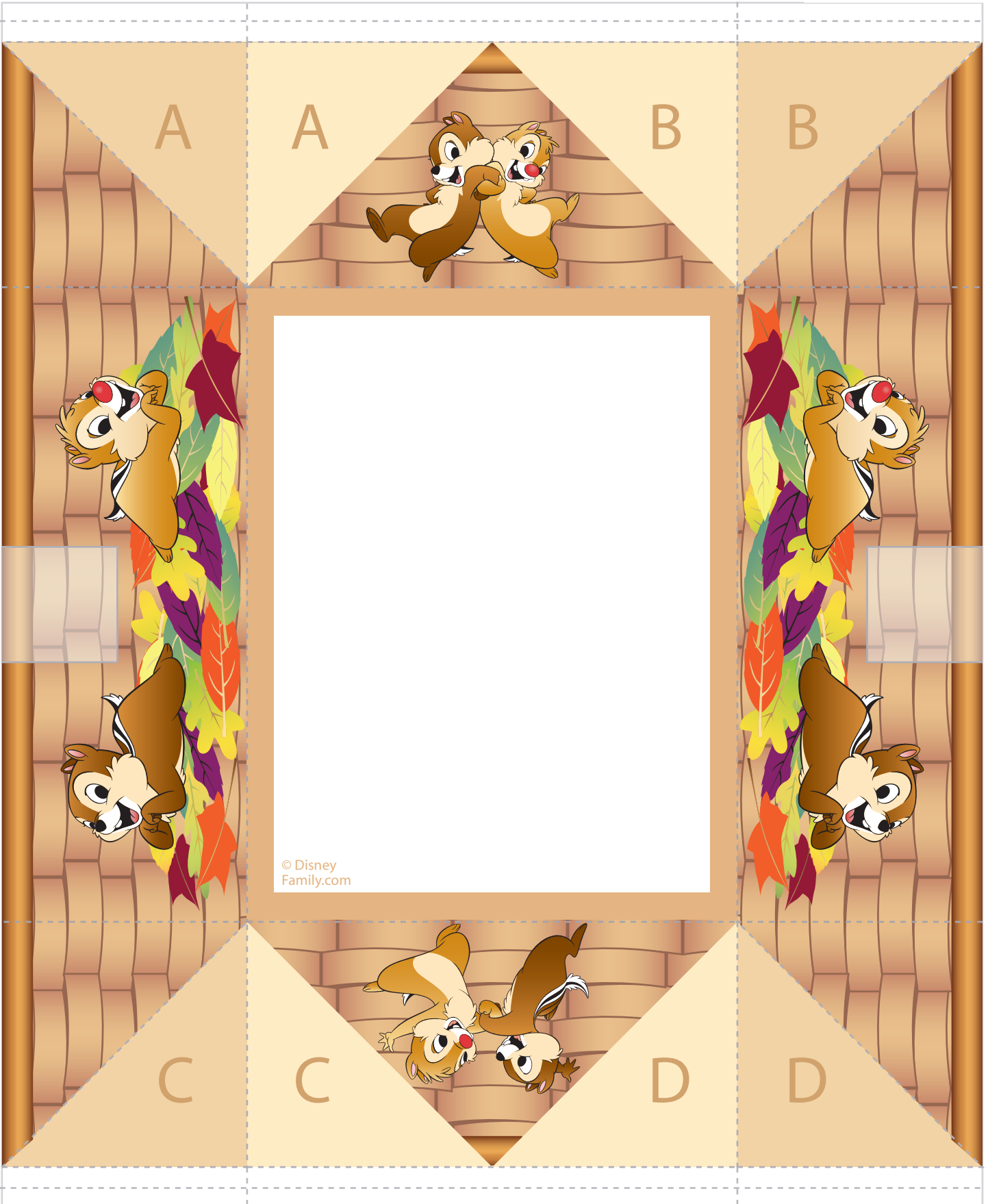

A

A

B

B

C

C

D

D

© Disney Family.com

fold away from you

fold away from you

1.

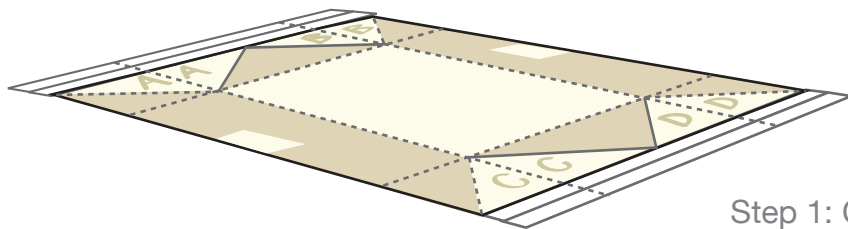

Step 1: Cut out the main piece of the basket.

2.

Step 2: Follow the fold indicators and graphics shown here and begin making your folds.

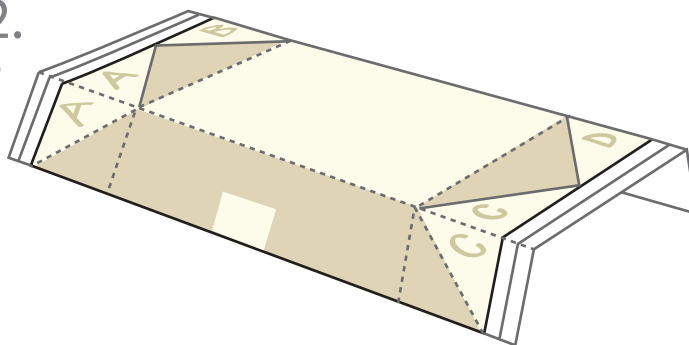

3.

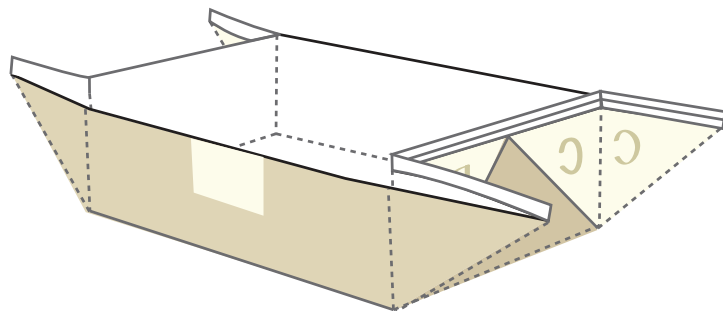

Step 3: Your basket should be starting to take shape. Glue “A” to “A” and so on until all four corners are secured.

Step 4: Fold over the white lip on the two sides of the basket. Cut out the handle and the characters. Glue the handle to the indicated sides of the basket. Cut out the leaves and acorns and hand one to each member of your family. Have them write what they are thankful for on the back. Place the notes in the basket and read them out loud after dinner.

4.

